

dynamic rubbers

PVT. LTD.



40+ 
Years of
Experience

52+ 
Exporting
Countries

30+ 
Product
Range

Product Catalogue

**Bulk Material
Handling Solutions**

Know more about us
www.dynamicrubbers.com

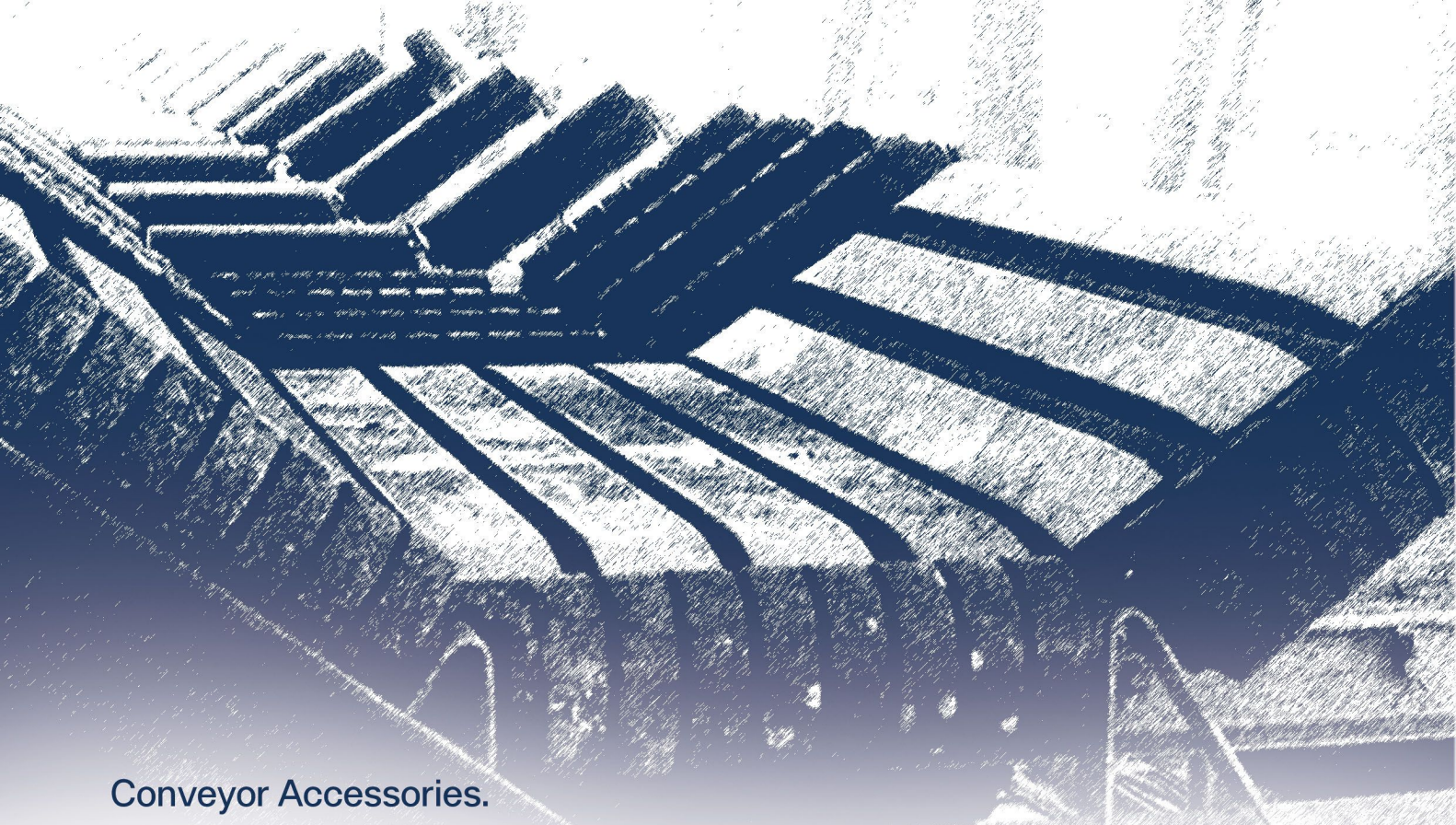

Conveyor Accessories.

Impact Bed

DYNAMIC's Impact Beds shield conveyor belts and systems from damage caused by heavy material impact. They are ideal for various industries, including mining (metal and non-metal), cement, and aggregate.

INDUSTRIES

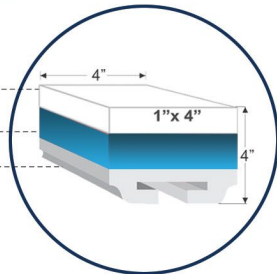
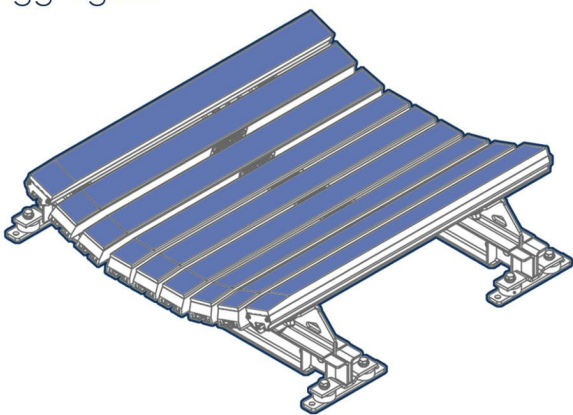

UHMW

SBR rubber

Aluminum Support

- ▶ **Improved Impact Cradles:** Utilizing our 17.5°, 10°, and 22.5° bars, eliminate pinch points and idler junction areas in various idler systems.
- ▶ **Absorbs Impact :** Featuring robust steel framework and impact bars made with shock-absorbent 40-durometer rubber for handling large materials.
- ▶ **Modular Designed :** Cradles are available in 2', 4', or 5' lengths based on impact area size.

Impact Cradle Beds

DYNAMIC's Impact Cradle Beds protect conveyor belts from damage caused by rocks, tramp metal, and more. Modular design ensures impact protection and spillage control in loading zones.

- ▶ Steel-reinforced impact bars with a bed of steel angles.
- ▶ Easy installation with adjustable supports matching trough angles.
- ▶ Eccentrics in wing supports compensate for wear, offering adjustment.
- ▶ Simple replacement with four-bolt securement per impact bar.

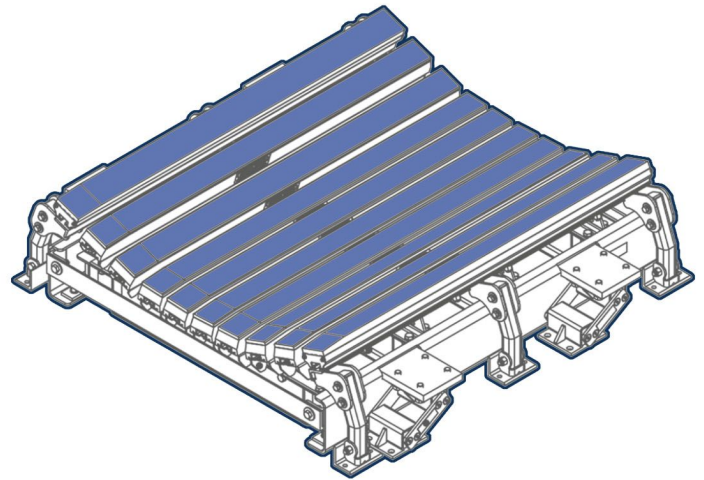

Impact Slider Beds

DYNAMIC offers suitable load zone solutions for various applications, from low-impact like sand to high-impact coal-related environments. We've engineered superior belt protection and unmatched serviceability in all of our slider beds and impact beds.

Rollers Slider Bed.

- ▶ Eliminates products spills
- ▶ Reduces dust accumulation & roller failure issues

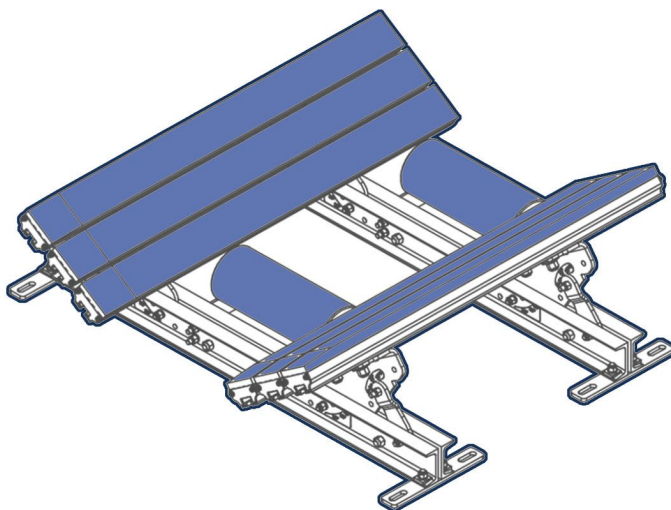

Impact Rollers Slider Bed.

- ▶ Absorbs the impact of large material.
- ▶ Supports the entire belt in the loading zones

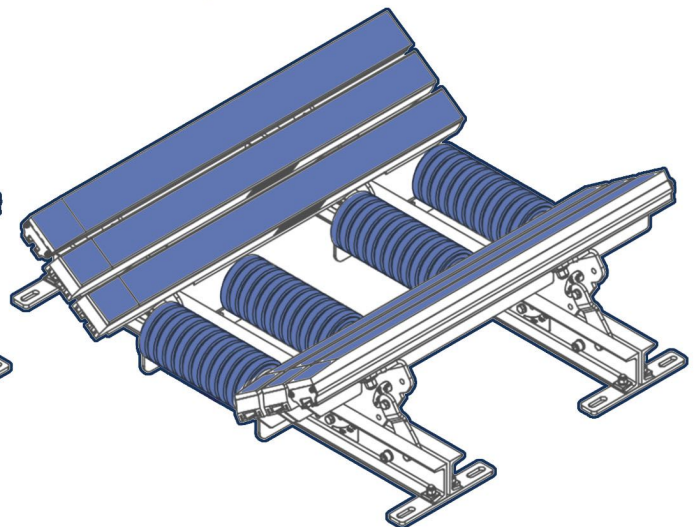

Modular Impact Beds

Designed for optimal capacity, DYNAMIC's Modular Impact Beds ensure complete load zone containment. With a 2' (600 mm) sectional base, the system empowers tailored impact zone design using all-bar sections for high-impact spots and slider impact sections for lower impact needs or sealing. When combined, these styles deliver peak load zone performance.

- ▶ **Effortless Maintenance :** Convenient slide-out trough and center section removal for swift and simple servicing.
- ▶ **Optimized Design :** Chamfered bars suitable for reversing belts ensure efficient functionality.
- ▶ **Peak Performance Fusion :** Seamlessly integrate slider and impact beds to achieve superior operational results.
- ▶ **Adaptable Trough Angles :** Adjustable at 20°, 35°, and 45° to meet varying needs.
- ▶ **Sectional Flexibility :** Utilize 2' (600 mm) sections for versatile load zone customization.

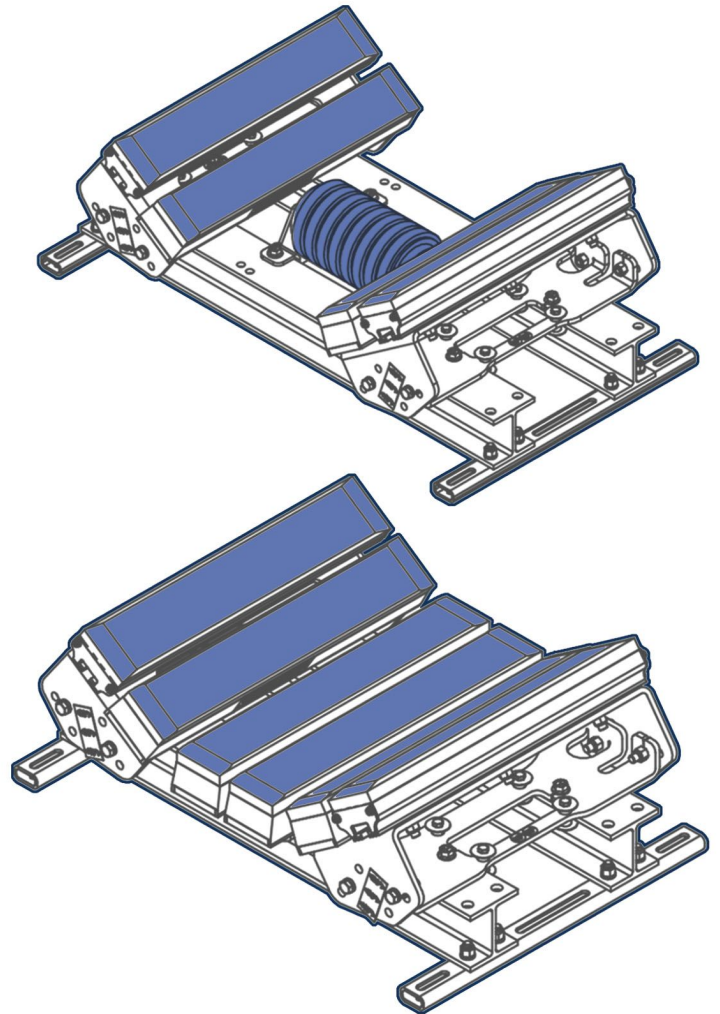

CONVEYER BELTING



Head office Near Hotel President, BLOCK-A, 904-905, Chimanlal Girdharlal Rd,
Navrangpura, Ahmedabad, Gujarat-380009
© +91 9662656666
© +91 77790 96913

Marketing@dynamicrubbers.com

Factory Dynamic Rubbers Pvt Ltd - Kheda Unit
(Conveyor belt and accessories Unit - 1)
Survey no. 217 paint,
Village: Ghodasar, Taluka: Mahemdavad,
District: Kheda, Landmark: Haldarvas
387110

Bharat Rubber industries - Kolkata Unit
(Conveyor belt Unit - 2)
Bodai panchayet road
Vill& Po : Jugberia
Kolkata 700110

**Conveyor
Rollers &
Pulleys
Unit.** Plot No. 3302,
Phase - IV, GIDC,
Vatva,
Ahmedabad - 382445

**Rubber
Products &
Belting
Unit.** D-111, Industrial Area ,
RIICO , Palsana ,
Dist . Sikar,
Rajasthan